

# Dividends Horizon



**Knoll**













**New Texture and Transparency for Shared Workspaces**

42"-high Open Weave Screens in Warpnet, Medium Grey, foreground, offset by the signature Dividends Horizon Triangular Frame in Bright White, energize workstations. Graphic Sliding and Flip Door Overheads, background, punctuate shared workspaces with 64"-high panels. Panels in Interknit, Gale; Overhead cabinets in Bright White. EWC Tech™ chairs, foreground, with Beige Taupe suspension back and Eclat Weave, Tangerine, seat cushion; EWC Sport™ chairs, background, in Harrison, Blair, with back and seat accent in EWC Sport Beige Taupe.

## **Spatially Aware.**

Dividends Horizon ushers in the next generation of one of the most popular Knoll office systems, energizing the workplace with new, pragmatic planning and aesthetic opportunities for linked workstations and individual offices.

Transcending a traditional systems aesthetic, Dividends Horizon creates a sense of community and space.



### Pragmatic Planning

For organizations seeking to simplify the furnishings process, Dividends Horizon leverages a minimum number of basic elements for straightforward workplace solutions that include work areas in combination with Sliding and Flip Door Overhead Storage and back-to-back 24"-high Credenzas. By orienting users at 90-degree angles, Dividends Horizon creates efficient, yet open, shared workstations.

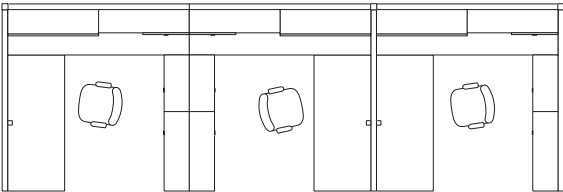

### Integrate Storage

64"-high Standard panels in Interknit, Gale, and 36"-high panels in Interknit, Spectra, with 14"-high Glass Screens with Triangular Frame; Sliding and Receding Door Overheads, left and above, define workstation clusters. Open Leg Worksurface Supports, right, provide a streamlined alternative to traditional end panel supports. EWC Sport chairs in Harrison, Blair, with back and seat accent in EWC Sport Beige Taupe.







## Linear and Luminous Low Horizons for the Open Plan

With strong horizontal lines and visual lightness, Dividends Horizon Open Weave Screens feature a triangular profile frame that offers depth and character for workstations. In combination with low horizon Standard panels, Open Weave Screens address the needs of organizations seeking more collaborative space in settings that leverage natural light.

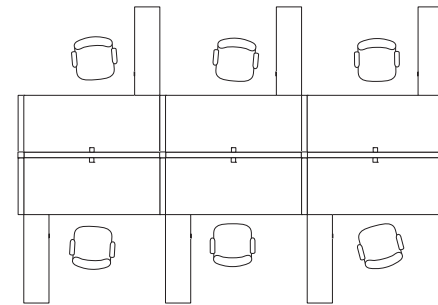

### Address Technology

Create an exceptionally light and technologically efficient workplace by combining 42"-high Open Weave Screens, right and above left, in Warpnet, Medium Grey, with 14"-high Glass Screens with Triangular Frame in Bright White. Define boundaries with 24"-high Credenzas. Panels in Interknit, Spectra, with 14"-high glass screens, below left, provide an alternate aesthetic. Technology Tiles, wire drops and grommets allow for power and data access above and below the worksurface edge.









### Illuminating the Interior Landscape

Dividends Horizon offers continuity between furniture and interior architecture, providing broad opportunities to plan workstations with access to natural light in mind. With a focus on optimizing users' relationships to their workstations and those around them, Dividends Horizon moves the workplace forward both practically and aesthetically.

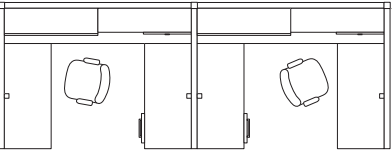

### Leverage Panel Options

Focus on the artful contrast of structure and materials with Dividends Horizon Open Weave Screens in Warpnet, White, above right, and the Triangular Legs of the Open Base Panel, left and below right, detailed to express a light and open aesthetic. Open Base Panels and Standard Raceway Panels, left, in Palladium, Talc. Life chairs with Currant Back Suspension Fabric and Alignment, Madder, seat cushion; mobile pedestal with cushion in Gibson, Cassis.





## Rich Spatial Effects

Dividends Horizon incorporates furniture elements that reflect contemporary work styles. Table Desks, Meeting Tables and Credenzas for individual and shared spaces complement the range of Dividends Horizon panel, worksurface and worksurface support options, including Open Leg Support.

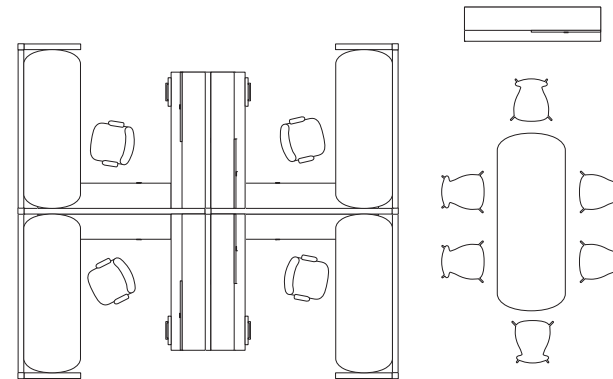

### Integrate Table Desks and Open Leg Support

Combine 36"-high Open Weave Screens, right, with a freestanding Table Desk in Cherry Techgrain for texture and lightness of scale. Meeting Table, above left, in White laminate with Tubular Brno chairs. 36"-high panels in Palladium, Talc, with Triangular Frame, below left, meet a standard 36"-high panel with 21"-high Open Weave Screens in Warpnet, White.











### Furniture Focused for the Private Office

Dividends Horizon incorporates contemporary furniture elements to create efficient yet classic private offices. Versatile in scope, Dividends Horizon offers not only flexibility but also aesthetic continuity among workplace applications, whether in the open plan, meeting room or private office.

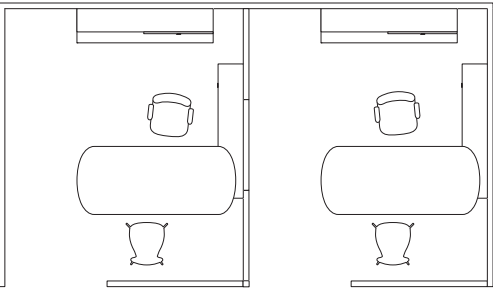

### Extend Material Options

Use a Table Desk in Cherry Techgrain, a 24"-high Credenza and a 64"-high sliding door Overdesk in Silver with 14"-high Cherry Techgrain door, to create an open, layered, individual workspace. Enhance privacy, left, with a single 64"-high glass screen, left, with Triangular Frame in Silver or use 64"-high panels, above right, in Palladium, Talc with 14"-high single pane windows.





### Streamlined Perspective

Dividends Horizon Meeting Tables create shared workspaces that maximize worksurface area. Meeting Tables and Table Desks are available in a variety of finishes and feature a signature floating leg. Calibre Storage Towers, trapezoid-shaped worksurfaces and Sliding Door Overdesks create graphic workstation geometry.

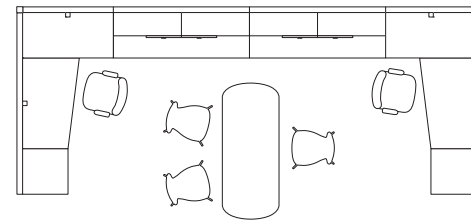

### Energize Workspaces

Define workstation boundaries for individual and shared meeting space, right, with a Meeting Table in Natural Techgrain featuring signature floating legs, and Sprite chairs in Maple with seat cushions in Eclat, Black. Tile-to-floor panels, bottom right, in Interknit, Gunmetal; Calibre Storage Towers and pedestals in Beige Mist Metallic.





# Dividends Horizon®

Dividends Horizon provides a full portfolio of easily reconfigured open and private office solutions, defining the workplace with pragmatic planning and new aesthetic opportunities. Designed by Jeffrey Bernett and Nicholas Dodziuk with David Noel.

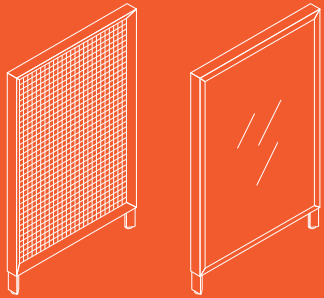

## Energize Workspaces with Open Weave and Glass Screens

With strong horizontal lines and visual lightness, Glass Screens and Open Weave Screens, incorporating an innovative structural textile by Suzanne Tick, set a new standard for delineating space between individual workstations.

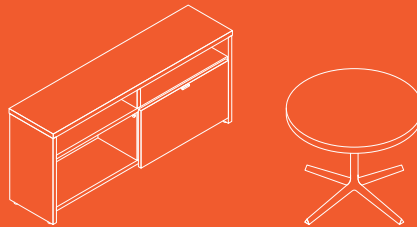

## Integrate New Furniture Elements and Practical Storage Solutions

Storage Towers, Sliding Door Overheads and Overdesks create graphic workstation geometry while fulfilling multiple storage requirements. Table Desks, Meeting Tables and Credenzas reflect contemporary work styles.

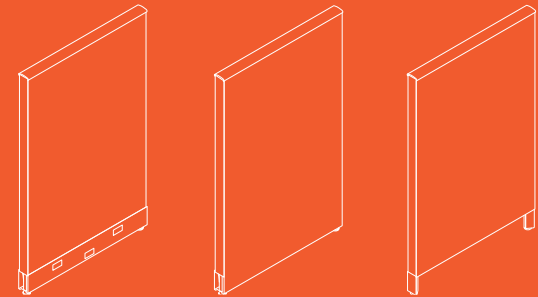

## Create Rich Spatial Effects with Three Panel Base Options

Dividends Horizon includes three base panel options: Standard, Tile-to-Floor and Open Base, which features triangular legs that enhance airflow while offering a lighter appearance.